

THIS COPY IS PROVIDED ON A RESTRICTED BASIS AND IS NOT TO BE USED IN ANY WAY DETRIMENTAL TO THE INTERESTS OF PANDUIT CORP.

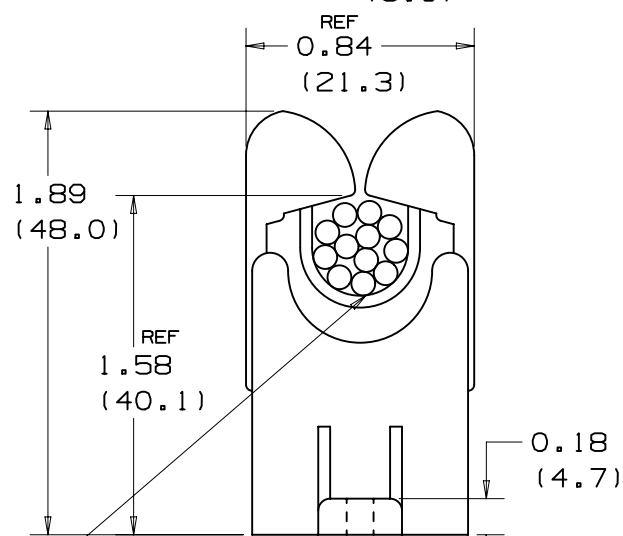

TYPICAL APPLICATION SHOWING BUNDLED WIRES

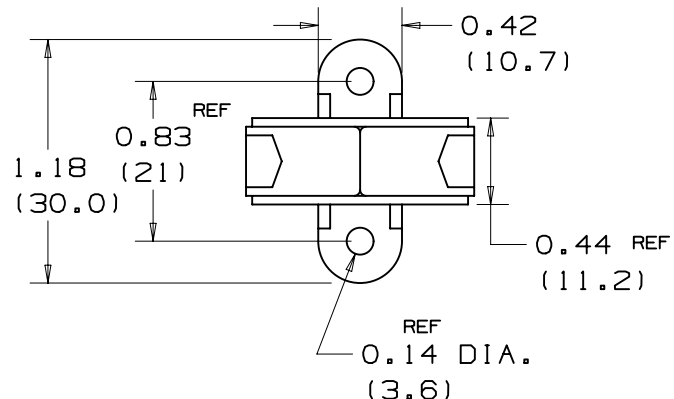
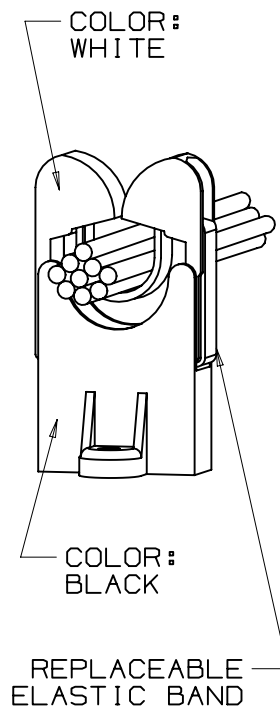

PANDUIT PART NO.	MAX. BUNDLE DIA. in/mm	RECM. FASTENER	WEIGHT lb/g/100 pcs
RER.5-S6	0.5 (12.7)	#6 SCRW. (M3)	1.6 (720)

NOTES:
1. SEE CURRENT PRICE SHEET FOR PART NUMBER SUFFIX DESIGNATION FOR PACKAGE SIZE

(DIMENSIONS IN PARENTHESES ARE IN METRIC.)

CAD FILENAME/LAYERS G00239HW_PB_RER.5_02

PANDUIT CORP. TINLEY PARK, ILLINOIS

ELASTIC RETAINER, RER.5-S6

UNLESS OTHERWISE SPECIFIED, DIMENSIONAL TOLERANCES ARE:
(.X) ±N/A (.XXX) ±N/A
(.XX) ±.020(.5) ANGLES ±5°

UNLESS OTHERWISE SPECIFIED, ALL DIMENSIONS ARE GIVEN IN INCHES, THIRD ANGLE PROJECTION.

DRAWN BY LGG

MAT'L:
NYLON BASE &
GLASS FILLED
RUBBER MODIFIED
NYLON 6/6 ARM

SCALE FULL

DATE 6/19/01

DRAWING NO. G00239HM

DWG SIZE A

CHK'D

REV	DATE	BY	CHK	DESCRIPTION	ECN	R	CUST	SUP
2	12/7/04	KLN		UPDATE ARM MATERIAL	GB0239HM	2		
1	7/21/03	JAD		UPDATE ARM MATERIAL	GB0239HM	1		
R	6/19/01	LGG		INITIAL RELEASE REPLACED SS-15049	GB0239HM	R		